



NOVA CONTROLS
LEADING THE WAY

A **Hydro** Systems Company

ECLIPSE

LAUNDRY DISPENSER CONTROLLER



Reference Manual

Programming and Operation



Online and Downloadable Product Manuals and Quick Start Guides are available at www.novacontrols.com/instructions.htm.

Don't bother digging around to locate that missing manual, take a look at our online version.

Table of Contents

1 Description of Features	
Description of Controls	2
Next, Scroll and Enter Keys	2
2 Installation	
Mechanical Installation	3
Electrical Installation	4
Auto Formula Select (AFS) Trigger Wiring	4
Programming the Washer Supply Signal	4
3 User Menus	
Modes of Operation	5
User Formula Select (Standard) Mode ($F[\#]$)	5
Auto Formula Select Mode (AFS)	5
Relay Mode ($F-r$)	5
Load Counter (LB)	5
User Prime (when enabled) ($P\prime$)	5
Formula Worksheet	6
Custom Wash Formula Wall Chart	6
4 Installer Menus	
Installer Programming	7
Password Access to Installer Menus	7
Using Control Keys in Installer Menus	7
Installer Menus	8
Installer Prime Pumps ($P\prime$)	8
Clear Load Counts (CLR)	8
Pump Calibration ($C-l$)	9
Program Formulas ($F-l$)	9
Pump Amount Number ($PA\prime$)	9
Pump Delay Time ($dL\prime$)	9
Finish Program ($F\prime n$)	10
Relay Mode ($F-r$)	10
Flush Time (FLu)	10
User Prime (UPr)	10
Pump Interlock ($P\prime l$)	10
Auto Formula Select (AFS)	10
AFS Mode Notes	11
Change Password ($P\prime n$)	11
Exit (End) or Reset to Factory Defaults [FRC]	11

5 Troubleshooting and Specifications

Preliminary Checks	13
Dead, No Display	13
No Pumps Run	13
No Pumps Prime	13
No Pumps on Trigger, Prime OK	13
Load Count Errors	13
<i>EPi</i> Displays in AFS Mode	13
Specifications	14
Ordering Information	14
Limited Warranty	14
Limitation of Liability	14

Description of Features

The ECLIPSE Controller uses the latest technology to provide low cost and reliable operation with full features. The following list outlines many of the ECLIPSE Controller's features:

Compatibility

The ECLIPSE Controller is fully compatible with Nova Controls Eclipse dispensing systems. The same easy-to-install modular design makes the ECLIPSE Controller suitable for use with components from earlier Orion dispensing systems. Everything is telco plug compatible.

Formula Power

You may program up to 8 different chemical formulas that are available for machine operator selection. Formula selection is done with only one front panel key (with an icon). Formulas can also be selected and started automatically with the Auto Formula Select feature. This formula power is more than enough for most OPL laundry operations.

Six Product Capability

The ECLIPSE Controller is capable of controlling up to 6 products with a flush manifold. Program pumps for dose amounts of up to 29.9 oz. in 0.1 oz. increments, or 995 mls in 5 ml increments.

Flush Capability

When used with an ECLIPSE pumpstand, a programmable output is available for controlling a flush manifold water valve. Flush time is easily programmed in seconds.

Auto Formula Select (AFS)

When used with a fully-programmable, microprocessor-controlled washer, the washer uses a timed signal to automatically select the chemical formula.

Pump Interlock

A Pump Interlock may be turned on for use on washers with multiple or noisy supply signals. When on, this feature allows only one programmed product dose per load, no matter how many times the washer sends a supply signal.

Relay Mode

Relay Mode operation is available for use with fully programmable washing machine control systems.

Load Counters

Loads for each formula are counted and can be reviewed when the Controller is in User Menus. A load is counted each time the load count pump runs. (The load count pump is the highest pump number within each formula for which an amount is programmed.) In Relay Mode (no formulas), a load is counted each time pump 1 is run.

Safe Wiring

The ECLIPSE dispensing system requires high voltage connections only at the Machine Interface (MI) to washer signal connections. All other wiring is plug-in with telephone type communication cables. Dispenser power is sourced from a wall outlet.

Water Resistant Enclosure

The ECLIPSE Controller case is water resistant. The telephone type jacks are well protected from sources of potential water damage.

Security

All dispenser programming is protected by a three-digit password. Once you assign your own password, access to the Installer Menus is only possible if you know the password or return the Controller to Nova Controls for clearing to factory settings.

Ease of Programming

Every step has been taken to simplify the programming menu structure to provide the fastest possible programming and system installation. Once all installed pumps are calibrated (one time per pump), you may then input pump amounts for each formula directly in ounces or milliliters.

Description of Controls

Next, Scroll and Enter Keys

The ECLIPSE Controller makes good use of only 3 keys and a 3-digit LED display for all dispenser operation and programming. Each key's function is described in this section.

NEXT Key – Move to the next item or task.

User Menus: Move through the available User Menus.

Installer Menus: Move through Installer Menus.

Input Screens: Move blinking digit to the right.

SCROLL Key – Change the blinking digit value.

User Menus: Change formula numbers.

Change “View Load Counter” formula numbers.

Change pump number in User Prime screen (when on).

Installer Menus: Change values of blinking digits.

Input Screens: Change values of blinking digits.

ENTER Key - Perform a task or set a value.

User Menus: Press and hold for 2 seconds to access Password input screen.

Start and stop selected pump number in User Prime (when on).

Installer Menus: Perform actions as prompted in Installer Menu.

Input Screens: Set the displayed value (selected with **NEXT** and **SCROLL** Keys).



Figure 1 Controller Keys

2 Installation

Mechanical Installation

When choosing a mounting location for the ECLIPSE Controller, select a location that is:

- On, or close to, the washer.
- Within easy reach of machine operators, who will select formulas and read the display.

The ECLIPSE Controller may be mounted on either a horizontal surface (such as the top of the washer) or a vertical surface (such as the front of the washer). You may mount the unit using either the self-adhesive velcro hooks (provided) or nuts and allen bolts (not provided), as shown in *Figure 2*.

Note 	This Controller manual only covers installation and programming of the ECLIPSE Controller. Please refer to the reference manual packed with your pumpstand or upgrade kit for additional instructions.
--	--

To mount the unit:

1. Place velcro on mounting surface, using Controller as a template.
2. Attach Controller to velcro. If using nuts and allen bolts, do not overtighten bolts.

Bolt Holes for Vertical Mounting
(hardware not provided)

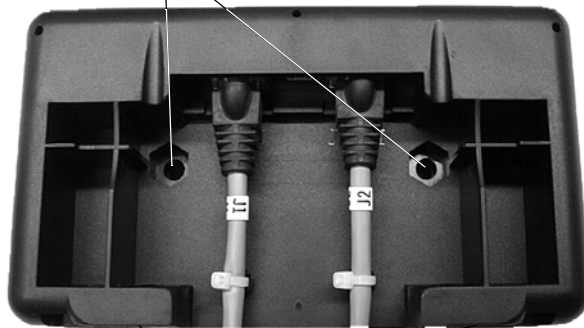

Bolt Holes for Horizontal Mounting (hardware not provided)

Figure 2 **Optional Bolt-Mounted Installation**

Electrical Installation

Caution 	Route J2 cable away from all washer high voltage wiring and contacts to minimize the chance of electrical interference. Route all cables in such a way as to minimize possibility of damage or kinking.
---	--

To connect the cables, follow these steps:

1. Connect the cable marked “J2” from the Machine Interface (MI) to the connector labeled “J2/MI” on the rear of the Controller.
2. Connect the cable marked “J1” from the pumpstand to the connector labeled “J1/PI” on the rear of the Controller.
3. Secure J1 and J2 cables to strain relief points with tie wraps (as shown in *Figure 3*).

Note 	The maximum allowable distance for the J1 Cable from the delivery module to the controller is 75 feet. Cables are available in standard lengths of 15, 30, 45, 60, and 75 feet.
--	---

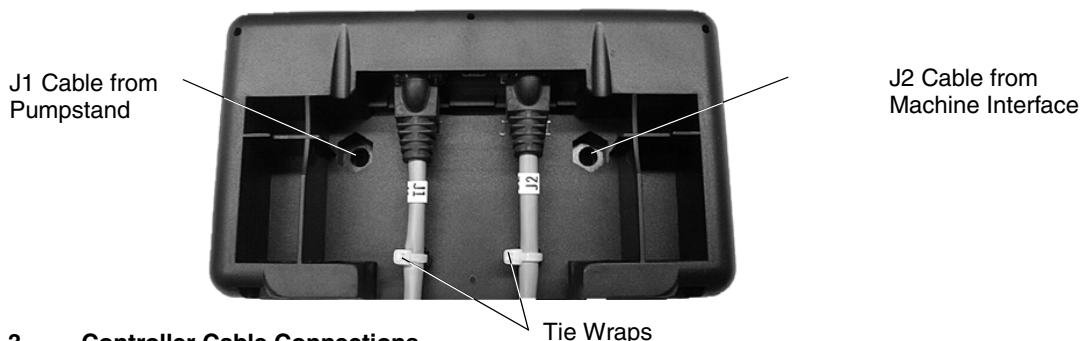

Figure 3 Controller Cable Connections

Auto Formula Select (AFS) Trigger Wiring

AFS allows the installer to choose a trigger signal number that will select and run any programmed formula with a timed signal. After a formula has begun, the AFS Trigger signal may also be used as a chemical pump trigger. **IMPORTANT:** If the AFS trigger will NOT also be used as a chemical pump trigger, the AFS trigger wire must be connected from the MI to the washer.

Programming the Washer Supply Signal

The washer supply signal must be programmed for a total of 2 seconds multiplied by the desired formula. For example:

- Formula 1 = 2 second signal
- Formula 2 = 4 second signal
- Formula 3 = 6 second signal, etc.

For more information on Machine Interface installation and supply trigger wiring, see the Reference Manual that was shipped with your pumpstand. These manuals can also be found on the Nova Controls website at www.novacontrols.com.

If you are using an Eclipse Pumpstand, see *Chapter 2* of the “*Eclipse Liquid Laundry Supply Dispenser Reference Manual*,” p/n 20-06108-00.

User Menus

The installer sets the Controller's Mode of Operation. The machine operator can view Load Counts (by formula or for all formulas) and, if allowed, can prime the pumps and select a formula to run. The **NEXT** Key moves between menus.

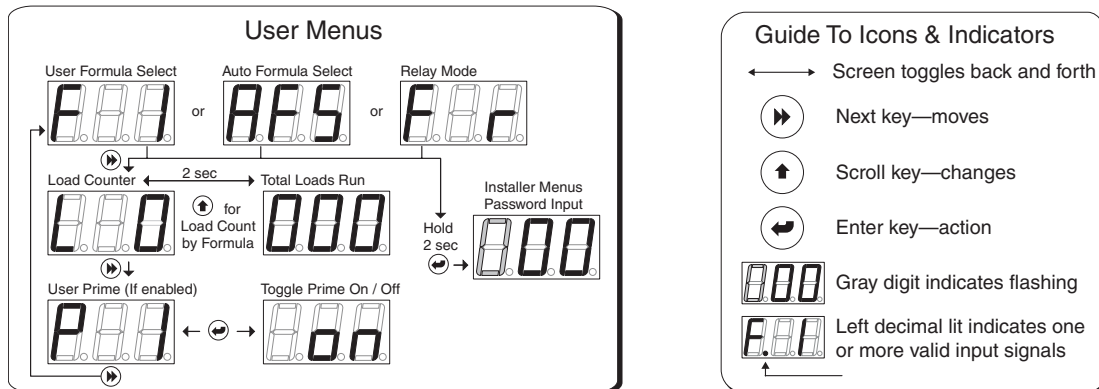

Figure 4 ECLIPSE User Displays and Menus

Modes of Operation

User Formula Select (Standard) Mode ($F [\#]$)

The currently selected formula $F [\#]$ displays when the controller is idle. Press **SCROLL** to select the formula number. If no formulas are programmed, $F 1$ displays as the default.

Auto Formula Select Mode (AFS)

If the installer has enabled Auto Formula Select, AFS displays when the controller is idle. When an AFS trigger signal is received, the controller automatically begins scrolling through the programmed formulas until the timed signal selects a formula. AFS again displays until the next, non-AFS signal occurs to start the wash cycle. The display then changes to the currently running formula (e.g. $F 1$). In AFS Mode, the operator cannot manually select a formula.

Relay Mode ($F r$)

If the installer has set the controller to Relay Mode, $F r$ displays when the controller is idle. Pumps run for the duration of supply trigger signal(s) and the operator cannot manually select a formula.

Load Counter by Formula ($L 0$)

$L 0$ = Total Load Count for all formulas. From $L 0$, press **SCROLL** to see the load count for a specific formula. $L 1$ = Load Count for Formula 1. The display toggles every 2 seconds between the selected formula number and the load count. After five minutes of inactivity, the screen returns to the Formula Selection screen set up by the installer.

User Prime (when enabled) ($P 1$)

1. From $P 1$ (User Prime), press **SCROLL** to change the pump number.
2. Press **ENTER** to turn pump on or off. Pump turns off automatically after 5 minutes of inactivity.

Formula Worksheet

Copy this worksheet and use it to record your formulas and as a reference to aid programming.

		FORMULA 1	FORMULA 2	FORMULA 3	FORMULA 4
PUMP #	PRODUCT	ON-TIME / DELAY	ON-TIME / DELAY	ON-TIME / DELAY	ON-TIME / DELAY
1					
2					
3					
4					
5					
6					
		FORMULA 5	FORMULA 6	FORMULA 7	FORMULA 8
PUMP #	PRODUCT	ON-TIME / DELAY	ON-TIME / DELAY	ON-TIME / DELAY	ON-TIME / DELAY
1					
2					
3					
4					
5					
6					

Custom Wash Formula Wall Chart

Copy and post this wall chart for the machine operator. Write the wash classifications for each formula.

CUSTOM WASH FORMULA CHART FOR: _____

Formula #	Application/Wash Classification
1	
2	
3	
4	
5	
6	
7	
8	

To Select Formula: Press the Scroll Key (↑)

Para Excojer la Formula: Oprima el Botón de la Voluta (↑)

Your Chemical Specialist Is: _____

Installer Programming

This chapter describes the functions that are set in the Installer Menu. A password is required for access to these functions:

- Installer Prime
- Clear Load Counts
- Pump Calibration
- Program Formulas
 - Relay Mode Selection
 - Pump Amount
 - Pump Delay Time
- Flush Time
- User Prime Enable
- Pump Interlock
- Auto Formula Select (AFS) and Trigger Number Selection
- Password Change
- Exit / Reset to Factory Defaults

Password Access to Installer Menus

1. From the Formula Selection screen, press and hold **ENTER** for 2 seconds to access the Password input screen.
2. Press **SCROLL** to change the blinking digit to the desired value.
3. Press **NEXT** to move the blinking digit and **SCROLL** to the desired value. Repeat for last digit.
4. When the desired number is present in all three digits, press **ENTER** to enter Installer Menus. The factory set password is 123.

Using Control Keys in Installer Menus

Press the **NEXT** key to move through the Installer Main Menu Loop. This loop contains most programming menus. A secondary menu loop, Program Formulas, is accessed after a formula number is selected in the main loop. The Program Formulas sub-menus are Pump Amount and Delay Time settings.

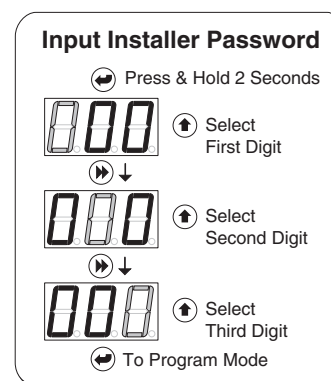

Note



The ECLIPSE automatically exits the Installer Menus, and returns to the User Menu's Formula Selection screen, after five minutes of inactivity.

Installer Menus

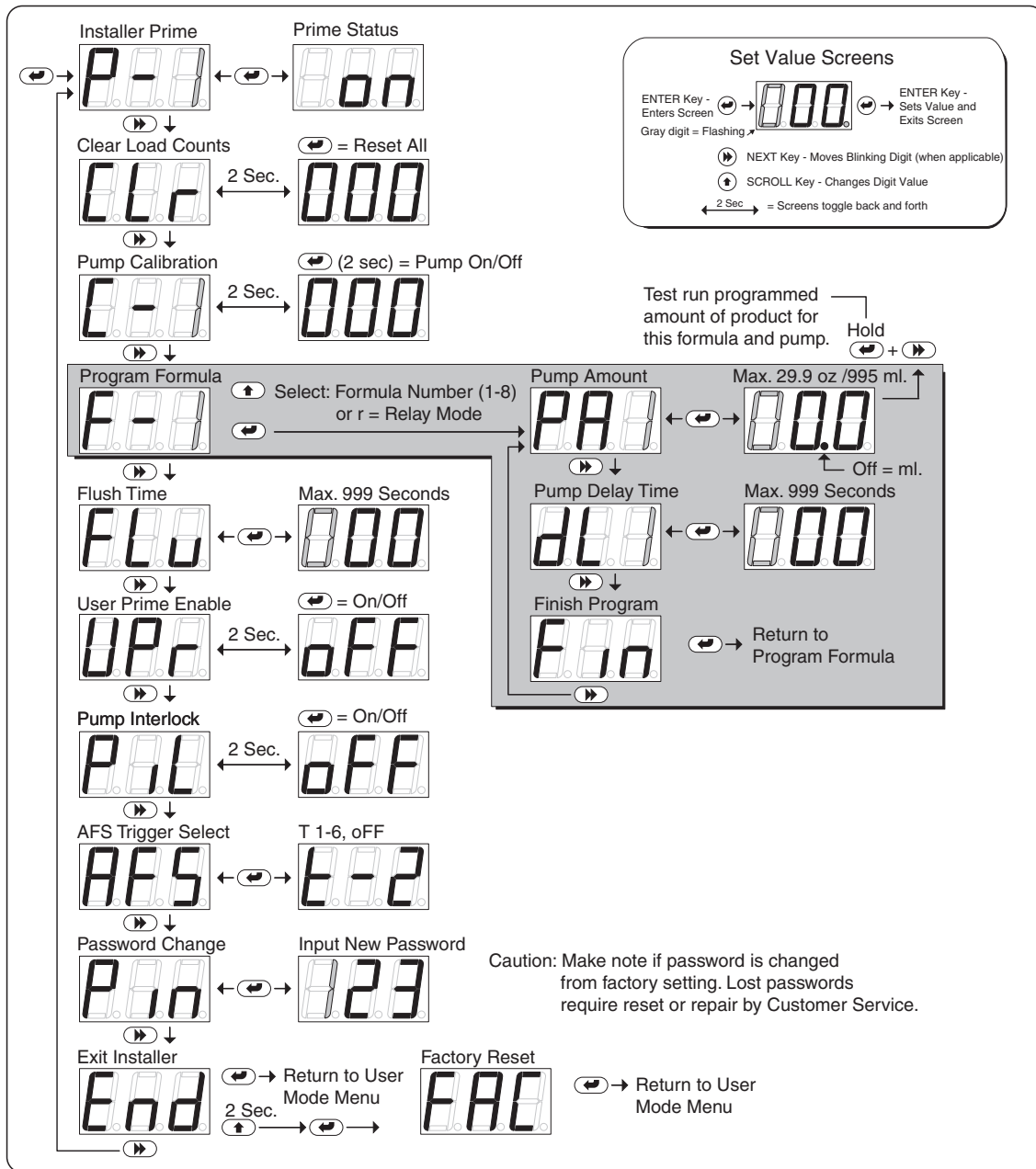

Figure 5 ECLIPSE Installer Menus

Installer Prime Pumps (P-r)

1. From the Installer Prime screen, press **SCROLL** to change the pump number.
2. Press **ENTER** to turn the pump on.
3. Press **ENTER** again to turn the pump off. Prime ends automatically if left on for 5 minutes.

Clear Load Counts (CLr)

Every 2 seconds, the screen alternates between CLr and the total load count for all formulas. Press **ENTER** to clear all load counts and reset the counter to zero.

Pump Calibration (C-i)

Note 	All installed pumps must be calibrated or they will not run when triggered.
--	---

Every 2 seconds, the screen alternates between C-[*pump number*] and the calibration value for that pump (the number of seconds it takes to pump 8 oz. of product). To set the pump calibration value, you must collect product in a container that is capable of measuring 8 oz.

1. Press **SCROLL** to select the pump number to calibrate. Place an appropriately sized container at the end of the discharge tube to collect product.
2. Press and hold **ENTER** for 2 seconds to start the pump. *on* is displayed. When container is filled with exactly 8 oz. of product, press **ENTER** again to stop the pump and store the calibration value.
3. Repeat for all installed pumps.

Program Formulas (F-i)

1. From the Formula Menu, press **SCROLL** to select a Formula Number F-[#] to program.
(Or, to select Relay Mode, **SCROLL** until F-r displays. Press **NEXT** to enable Relay Mode. See "Relay Mode (F-r)" on page 10.)
2. With a formula number blinking, press **ENTER** to access the Pump Amount Number screen PA[#].

Pump Amount Number (PAi)

1. With the Pump Number blinking, press **SCROLL** to reach the desired pump number to program.
2. Press **ENTER** to access the Pump Amount input screen (in ounces) for that pump number.
3. Press **SCROLL** to change the blinking digit's value.
4. Press **NEXT** to move the blinking digit. Repeat for all digits.
5. Press **ENTER** when the desired amount displays. The maximum amount is 29.9 oz. (995 ml.).
6. Repeat for all pumps that will run in the selected formula.

To Test Run a Pump Amount

1. From the Pump Amount screen (PAi), press and hold **ENTER**. (The input screen will appear.)
2. While still holding **ENTER**, press and hold **NEXT**. Continue pressing both keys to activate the pump for the programmed time. *on* is displayed. The pump stops automatically after a dose has been delivered. Release both keys.

Pump Delay Time (dLi)

Set time (maximum 999 seconds) for the pump to wait after receiving a trigger signal and before dispensing product. Delay Time allows the washer to fill before dispensing product onto dry linen.

1. From the Pump Amount screen, press **NEXT** to reach the Pump Delay Time screen.
2. Press **SCROLL** to select a pump number.
3. Press **ENTER** to access the Pump Delay Time input screen for that pump.
4. Press **SCROLL** to change the blinking digit's value.
5. Press **NEXT** to move the blinking digit. Repeat for all digits.
6. Press **ENTER** when the desired time displays.
7. Repeat for all chosen pumps in the selected formula.

Finish Program (F_{rn})

1. Press **NEXT** and F_{rn} is displayed. Press **ENTER** to return to the Program Formula screen.
2. To select another formula, press **SCROLL** to reach that formula number, then press **ENTER** to access the Pump Amount and follow the previous instructions.
3. To exit and set Flush Time, when F_{rn} is displayed, press **ENTER**, then press **NEXT**.

Relay Mode ($F-r$)

Note 	Available for use with fully programmable washing machine control systems.
--	--

In Relay Mode, pumps run for the duration of supply trigger signal(s). The load counter counts a load each time pump 1 is run. The User Menu displays $F-r$, to indicate that no formula can be selected.

1. From the Program Formulas screen, press **SCROLL** until $F-r$ displays.
2. Press **NEXT** to choose Relay Mode of operation and exit formula programming.

Flush Time (FLU)

1. Press **Enter** to access the Flush Time input screen.
The maximum programmable time is 999 seconds. A display of 000 indicates that flush is off.
2. Press **Scroll** to change the blinking digit's value.
3. Press **Next** to move the blinking digit. Repeat for all digits.
4. Press **Enter** when the correct flush time displays. This sets the flush time.

User Prime (UPr)

Every 2 seconds, the screen alternates between UPr and the setting (on/off). When User Prime is set to on , the user can prime pumps while in User Menus.

- Press **ENTER** to change the setting.

Pump Interlock (PiL)

Every 2 seconds the screen alternates between PiL and the Pump Interlock setting (on or off).

When on, the Pump Interlock allows only the first supply signal in the washer cycle to activate a pump. All additional washer signals (e.g. from multiple or noisy supply signals) are ignored until the load count pump runs or a one hour time limit is reached.

- Press **ENTER** to change this setting.

Auto Formula Select (AFS)

AFS allows a trigger signal from the washer to automatically select a programmed formula with a timed signal. AFS cannot be used with Relay Mode, nor can AFS utilize a trigger signal that starts or ends a formula cycle (the first pump triggered starts the formula cycle and the count pump ends the formula cycle). The AFS trigger signal must occur before a wash cycle begins or after a wash cycle has ended, not while a formula is running. See also "*AFS Mode Notes*" on page 11.

To set the AFS trigger (and enable Auto-Formula Select):

1. Press **ENTER** to access the trigger input screen.
2. Press **SCROLL** until the correct AFS trigger ($t-1$ through $t-5$) displays. The AFS default is off .
3. Press **ENTER** to set the displayed trigger and return to the AFS menu.

To select a particular formula when in AFS Mode, the installer must program the washer supply signal for a total of 2 seconds multiplied by the desired formula number. For example:

Formula 1 = 2 second signal (1 x 2 seconds = 2)

Formula 2 = 4 second signal (2 x 2 seconds = 4)

Formula 3 = 6 second signal (3 x 2 seconds = 6), etc.

AFS Mode Notes

1. If the AFS trigger is also used as a pump trigger, allow for at least three (3) seconds after the first trigger before using the AFS trigger as a pump trigger.
2. Pump triggers and the AFS trigger are ignored when the controller is in the User Prime menu.
3. In AFS mode, the controller automatically exits the Load Counter display upon receiving a pump or AFS trigger signal.

Change Password (*P_{in}*)

1. From the Password Edit screen (*P_{in}*), press **ENTER** to access the Password input screen. Any three digit number may be chosen as the new password.
2. Press **SCROLL** to change the blinking digit's value, then press **NEXT** to move the blinking digit. Repeat for all digits.
3. Press **ENTER** to set the new password and return to the main menu.

Caution 	Note the new password). If your password is lost, it must be returned to Nova Controls for reprogramming.
---	---

Exit (*End*) or Reset to Factory Defaults [*FAC*]

From the *End* screen, press **ENTER** to return to User Menu's Formula Selection Screen, or press **NEXT** to return to Prime Pumps.

To clear Controller settings and restore the factory default settings:

1. Press and hold **SCROLL** for 2 seconds. While still holding **SCROLL**, also press **ENTER**. The Factory Reset screen will display *FAC*.
2. Press **ENTER** again to return to the User Menu's Formula Selection Screen.

This page intentionally left blank.

5 Troubleshooting and Specifications

Preliminary Checks

Please perform the following checks prior to proceeding with the troubleshooting tips provided:

- All cables are securely connected.
- All pumps are calibrated and formulas are programmed.
- Correct mode of operation is selected (User Formula Select, AFS or Relay).

Dead, No Display

- Check to see if Controller is connected to delivery module via J1 cable.
- Check to see if power is connected to pumpstand.
- Check to see if pumpstand circuit breaker is tripped.

No Pumps Run

When pumps do not run, it is important to differentiate between running on prime and running from a machine trigger. Pumps only run formula amounts from a machine trigger when pumps are calibrated. In flush mode, only one pump may run at a time. Multiple pumps triggered at the same time run in queue.

When only certain pump positions are defective, check:

- Pump Interface (PI)
- Printed circuit board (PCB)
- J1 Cable connections.

No Pumps Prime

- Confirm pump wiring harness is connected to PI PCB in pumpstand.
- Follow troubleshooting procedures in pumpstand manual for PI PCB defect.

No Pumps on Trigger, Prime OK

- Make sure that pumps are calibrated.
- Check for a delay time programmed, or if pump is in queue.
- Check for a trigger signal. Confirm by viewing lights on M. I. & measuring signal with volt meter.
- Follow pumpstand manual troubleshooting procedures for MI defect.
- Test run pump amounts as described in *“To Test Run a Pump Amount” on page 9.*

Load Count Errors

To assure correct load counts, check for proper sequencing between washer supply signals and the controller. In User Formula Select and in AFS Modes, a load is counted when the highest pump number that is programmed within the formula is triggered. In Relay Mode, a load is counted when pump 1 is triggered.

If load counts are low, check washer trigger signals or check if machine operator is short cycling the washer.

If load counts are high, check washer trigger signal for count pump running more than once each load.

ERR Displays in AFS Mode

ERR displays if the AFS trigger signal tries to select a formula that is not programmed. The ERR message no longer displays when a valid formula is selected or when the unprogrammed formula is programmed.

Specifications

Note 	Specifications subject to change without notice.
--	--

Dimensions	
Size	6.3" Wide x 3.5" High x 2.0" Depth
Weight	.75 lbs.
General	
Temperature	120° F Maximum
Power	Provided by ECLIPSE system Pump Interface printed circuit board via J1 communication cable.

Ordering Information

ECLIPSE Controller, SAE Units	01-05970-00
ECLIPSE Controller, Metric Units	01-05970-01

Limited Warranty

SELLER warrants solely to BUYER the Products will be free from defects in material and workmanship under normal use and service for a period of one year from the date of completion of manufacture. This limited warranty does not apply to (a) hoses; (b) and products that have a normal life shorter than one year; or (c) failure in performance or damage caused by chemicals, abrasive materials, corrosion, lightening, improper voltage supply, physical abuse, mishandling or misapplication. In the event the Products are altered or repaired by BUYER without SELLER'S prior written approval, all warranties will be void.

NO OTHER WARRANTY, ORAL, EXPRESS OR IMPLIED, INCLUDING ANY WARRANTY OF MERCHANTABILITY OR FITNESS FOR ANY PARTICULAR PURPOSE, IS MADE FOR THESE PRODUCTS, AND ALL OTHER WARRANTIES ARE HEREBY EXPRESSLY EXCLUDED.

SELLER'S sole obligation under this warranty will be, at SELLER'S option, to repair or replace F.O.B. SELLER'S facility in Watsonville, California any Products found to be other than as warranted.

Limitation of Liability

SELLER'S WARRANTY OBLIGATIONS AND BUYERS REMEDIES ARE SOLELY AND EXCLUSIVELY AS STATED HEREIN. SELLER SHALL HAVE NO OTHER LIABILITY, DIRECT OR INDIRECT, OF ANY KIND, INCLUDING LIABILITY FOR SPECIAL, INCIDENTAL, OR CONSEQUENTIAL DAMAGES OR FOR ANY OTHER CLAIMS FOR DAMAGE OR LOSS RESULTING FROM ANY CAUSE WHATSOEVER, WHETHER BASED ON NEGLIGENCE, STRICT LIABILITY, BREACH OF CONTRACT OR BREACH OF WARRANTY.

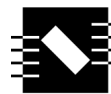

NOVA CONTROLS
LEADING THE WAY

A Hydro Systems Company

225 WESTRIDGE DRIVE
WATSONVILLE, CALIFORNIA
95076-4168 U.S.A.

N. AMERICA 800.252.6682
WORLDWIDE 1.831.786.1470
FAX 1.831.786.1650

<http://www.novacontrols.com>