

TECHNICAL DATA

Product type	Reverse osmosis watermaker
Application	Seawater for nautical application
Production	100 l/h \pm 15% (26,4 gal/h \pm 15%) @35 ppm and 25 °C
Membranes	2x Membrane SW-4021
Rejection	99,5% (nominal)
Power supply	12 V \pm 15% DC 24 V \pm 15% DC 48 V \pm 15% DC 110 V \pm 15% AC - 60 Hz 230 V \pm 15% AC - 50/60 Hz
Absorption - Power required	33 A \pm 15% - 400 W \pm 15% (12 V) 17 A \pm 15% - 400 W \pm 15% (24 V) 11 A \pm 15% - 400 W \pm 15% (48 V) 5,3 A \pm 15% - 600 W \pm 15% (110 V) 2,5 A \pm 15% - 600 W \pm 15% (230 V)
Pump	Rotary pump
Pressure pump	7-8 bar
Flow rate pump	15,6 - 16,6 l/min
Water inlet temperature range	8 - 30 °C
Pre-filtration	1x 5micron filter 10"x2-1/2" 1x Active carbon filter 2-7/8" x 9-3/4"
Weight	53 Kg
Shipping dimensions	88x64x69 cm



HYDRAULIC CONNECTIONES

PUMP / FILTERS / NR VALVE

Seawater inlet	Hose barb DN20/22 - DN20
Seawater outlet	Hose barb DN20/22 - DN20

WATERMAKER

Seawater inlet	Hose barb DN20/22
Concentrated water outlet	Hose barb DN16
Fresh water outlet	Compression fitting 1/4" for hose 6x8

CONTROL SYSTEMS AND OPTIONAL DEVICES

Electronics	Basic / Minitouch / Touch
Automatic flushing	Standard
Safety control	High/low pressure Low voltage
Salinity monitoring	N.A. (Basic) / Optional (Touch)

COMPONENTS

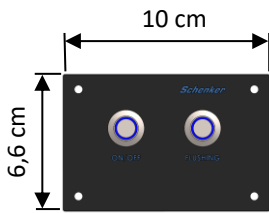

CONTROL PANEL (BASIC)
Depth: 3,2 cm
Cut dimensions: 7,6x4,4 cm

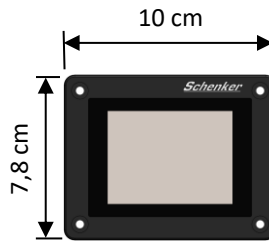

CONTROL PANEL (MINITOUCH)
Depth: 3,2 cm
Cut dimensions: 7,9x5,6 cm

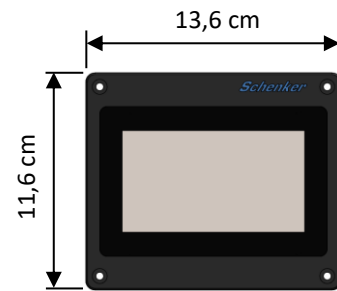

CONTROL PANEL (TOUCH)
Depth: 3,2 cm
Cut dimensions: 11x8,8 cm

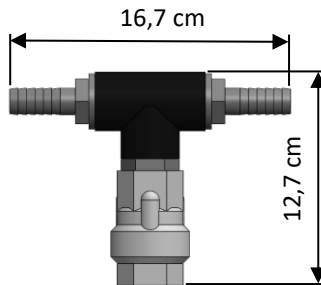

NON-RETURN VALVE
Depth: 4,7 cm

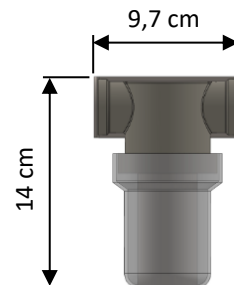

MESH FILTER GROUP
Depth: 9,1 cm

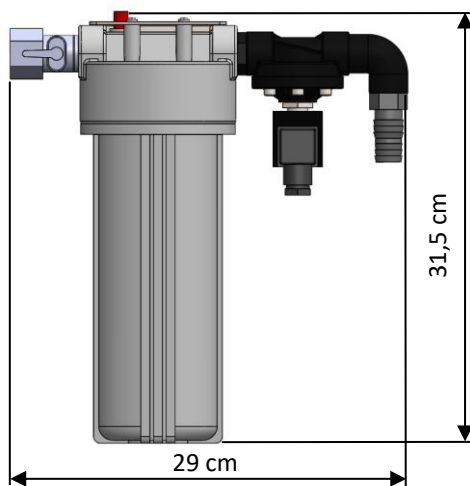

ACTIVE CARBON FILTER GROUP
Depth: 12,8 cm

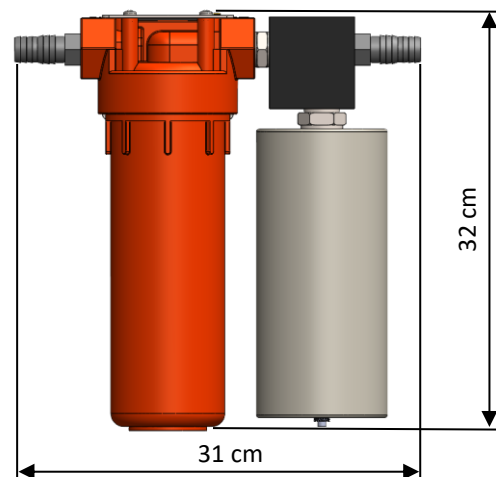

5 MICRON FILTER GROUP
Depth: 11,3 cm

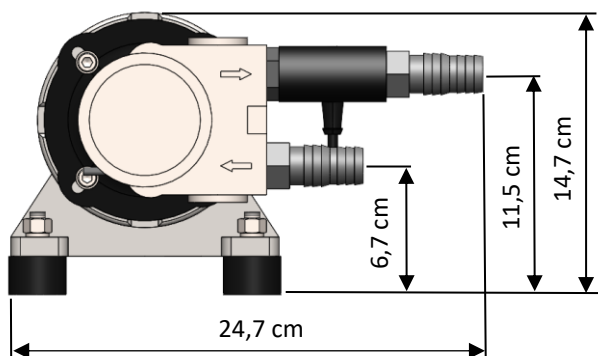

PUMP GROUP 12/24/48V
Depth: 37,1 cm - Weight: 10,1 kg

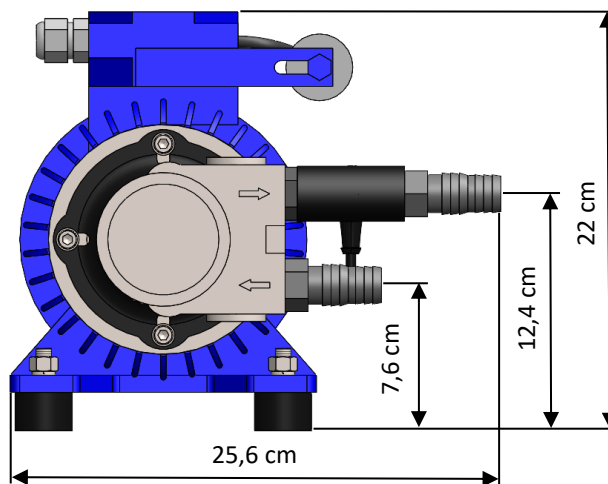

PUMP GROUP 230V
Depth: 40,4cm – Weight: 12kg

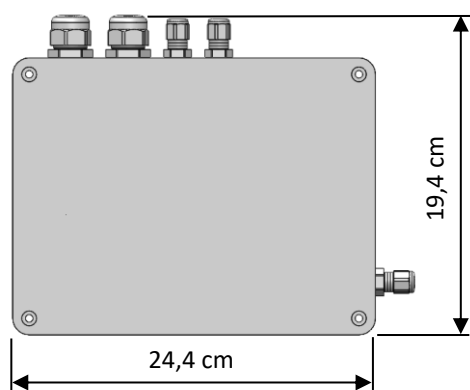

ELECTRICAL PUMP BOX
Depth: 10,6 cm

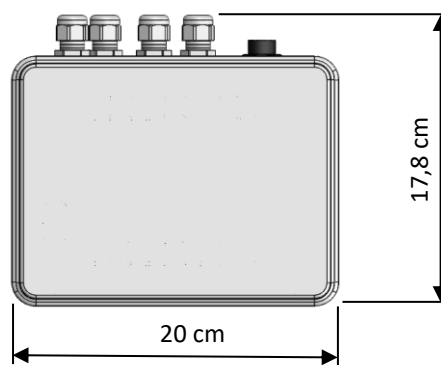

COMPUTER BOX (TOUCH)
Depth: 8 cm

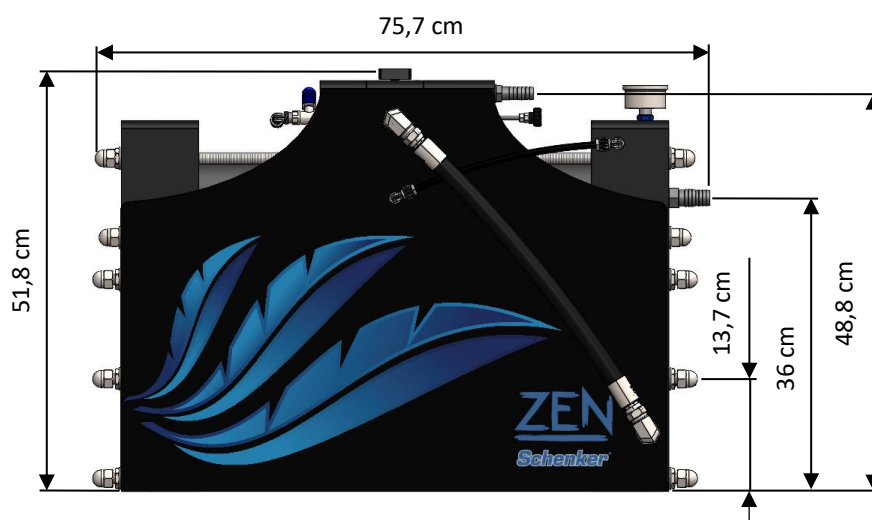

WATERMAKER
Depth: 19 cm - Weight: 40,8 kg

INSTALLATION SCHEME

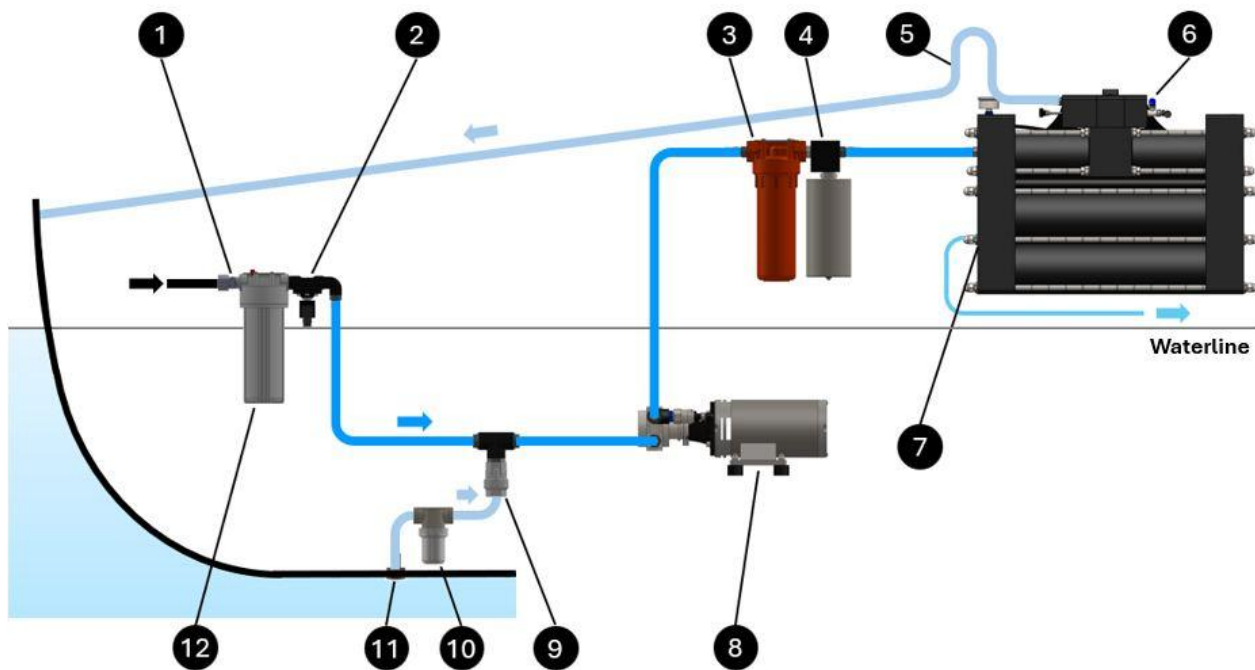

- | | |
|--|---|
| <ul style="list-style-type: none"> 1 Pressurized fresh water valve 2 Electrovalve 3 5 micron filter 4 Accumulator 5 Swan neck upwater - Discharge 6 Watermaker | <ul style="list-style-type: none"> 7 Fresh water outlet 8 Pump 9 Non return valve 10 Mesh filter 11 Sea water inlet 12 Active carbon filter |
|--|---|

Postadress:

TRÄDGÅRDSTEKNIK AB
 Helsingborgsvägen 578, Varalöv
 262 96 ÄNGELHOLM

Telefon : 0431-222 90
 Bg.nr : 5743-7980
 Org.nr : 556409-6120

URL:

www.tradgardsteknik.se
 E-postadress:
info@tradgardsteknik.se